

High Standards. Fully Loaded



Walk-in Van Bodies
with Workhorse Custom Chassis

**MORGAN
OLSON**



The E-track moves up and down for easy customization.



Our cargo packages attach and adjust to the vertical sidewall stiffeners, using spring-loaded nuts, for infinite flexibility.



Cargo shelving available in a fixed or folding position.

Durable and Reliable.

By teaming up with Workhorse Custom Chassis, we are able to provide you the most durable and long-lasting aluminum delivery vehicle in the industry today. With a wide array of standard features and available options to choose from, we personalize your order to meet your business's needs.

Standard Features:

- Durable, long-lasting, aluminum body
- Extruded aluminum floor with 10" wheel boxes
- Lift-up aluminum hood
- LED clearance and marker lights
- Interior sliding cab doors
- Sliding sash windows on R/L doors
- High-back cloth driver seat with lumbar support
- 48,000 BTU heater/defroster with recirculation function
- 8" deep steel bumper with diamond plate surface
- Exterior dual head mirrors with black finish
- Cab and (1) cargo dome light with switch on dash
- Incandescent lights recessed in kick plate
- Halogen headlights
- Mud flaps
- Twin 19" rear swing doors
- Aluminum roof
- Undercoating

Available Options:

- Cab air conditioning
- AM/FM radio
- Aluminum bulkhead with center sliding door
- Door-less driver
- 12V power source in dash
- Jump seat – removable or bulkhead mounted
- Additional passenger seating
- Power and non-power roof vents
- Additional cab or cargo dome lights
- Exterior LED stop, tail, turn and back-up lights
- E-track on cargo walls
- Cargo floor overlays center aisle or full width with .080" aluminum diamond plate
- Rear bumpers with grated surface, 8" or 10" deep
- Liftgates
- Multiple cargo packages
- Back-up camera



Standard driver seat with optional cloth covering and armrests, aluminum bulkhead with center sliding door, covered with optional sound reduction material, and optional bulkhead mounted jump seat.



Morgan Olson offers multiple paint schemes, installs graphics packages and offers liftgates.

Dimensions

Chassis		W42	W42	W42	W42	W42/ W62	W42/ W62	W42	W42/ W62	W42/ W62	W42	W42/ W62	W62	W62	W62	W62
Wheelbase	WB	125"	133"			157"			178"		190"		208"		218"	
Body Length		10'	11'	11'4"	13'	14'	15'	15'4"	16'	18'	18'	20'	20'	22'	20'	22'
Front of Cargo Floor to Rear	LL	125.5"	137.5"	144"	161.5"	173.5"	185.5"	189.5"	197.5"	221.5"	221.5"	245.5"	245.5"	269.5"	245.5"	269.5"
Bulkhead to Rear		120"	132"	136"	156"	168"	180"	184"	192"	216"	216"	240"	240"	264"	240"	264"
Interior Width (W62 is 93" Only)		86"/93"	86"/93"	86"/93"	86"/93"	86"/93"	86"/93"	86"/93"	86"/93"	86"/93"	86"/93"	86"/93"	93"	93"	93"	93"
Interior Height (W62 is 85" Only)	IH	73"/81"	73"/81"/85"	73"/81"/85"	81"/85"	81"/85"	81"/85"	81"/85"	81"/85"	81"/85"	81"/85"	81"/85"	85"	85"	85"	85"
Bulkhead to Wheel Well	CW	50.75"	58.75"	58.75"	82.75"	82.75"	82.75"	82.75"	103.75"	103.75"	115.75"	115.75"	133.75"	133.75"	143.75"	143.75"
Wheel Box Length		40"														
Back of Wheel Box to Rear	WR	29.25"	33.75"	37.25"	33.25"	45.25"	57.25"	61.25"	48.25"	72.25"	60.25"	84.25"	66.25"	90.25"	56.25"	80.25"
Width Between Wheel Wells*		41"														
Step Height at Cab**	SF	15"														
Step Height at Rear**	SR	20"														
Overall Length	OL	231"	243"	247"	267"	279"	297"	301"	309"	333"	333"	357"	357"	381"	357"	381"
Overall Height	OH	106" (73" Interior) / 114" (81" Interior) / 118" (85" Interior)														

* 48" on SRW ** W62 add 2"-3"

Please note body dimensions may change from model year to model year.

Doors

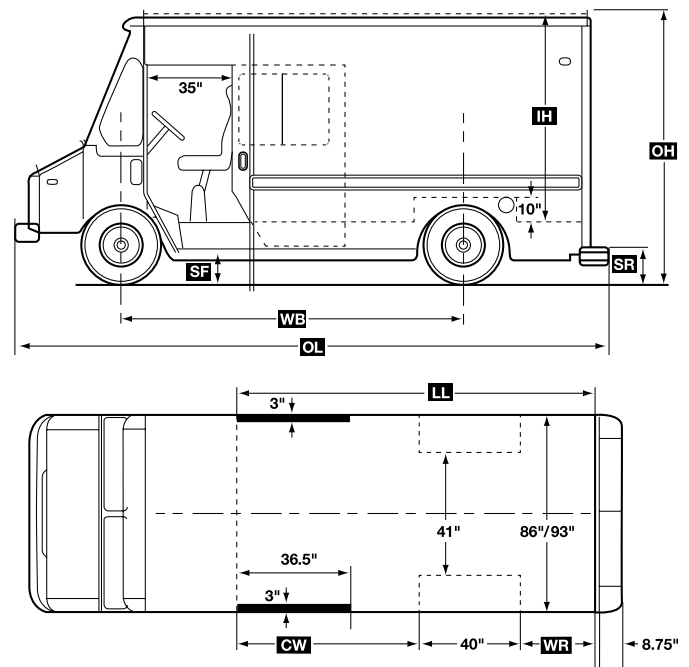
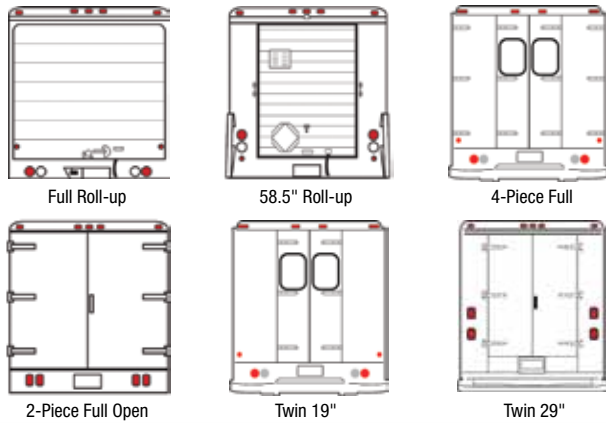

1801 South Nottawa Street
Sturgis, MI 49091
800.624.9005

MORGAN
OLSON
WWW.MORGANOLSON.COM